

# Discover the Mushroom

## Examine Mushroom Features

This Book Belongs To:

---

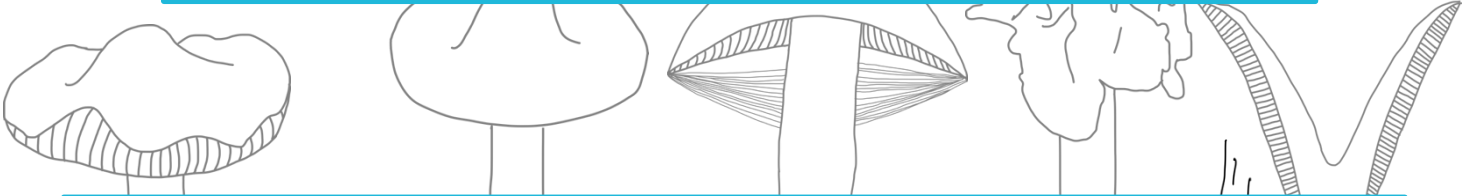

These mushrooms have been reviewed

Mushroom Number

Pen Color

Result: Mushroom Name

<hr/>	<hr/>	<hr/>
<hr/>	<hr/>	<hr/>
<hr/>	<hr/>	<hr/>
<hr/>	<hr/>	<hr/>



Overview Illustration of Classic Cap Mushrooms

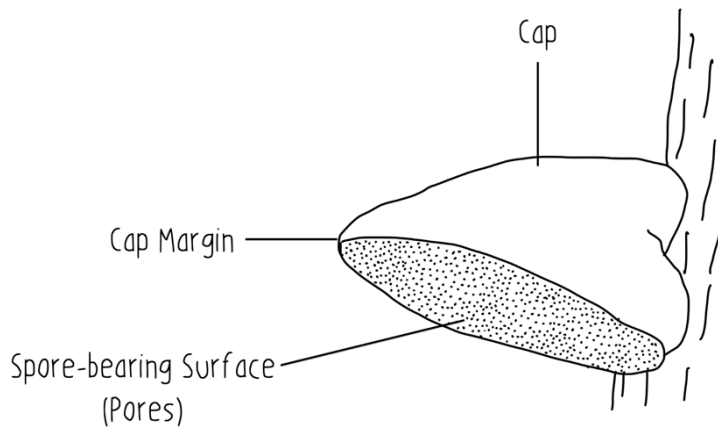
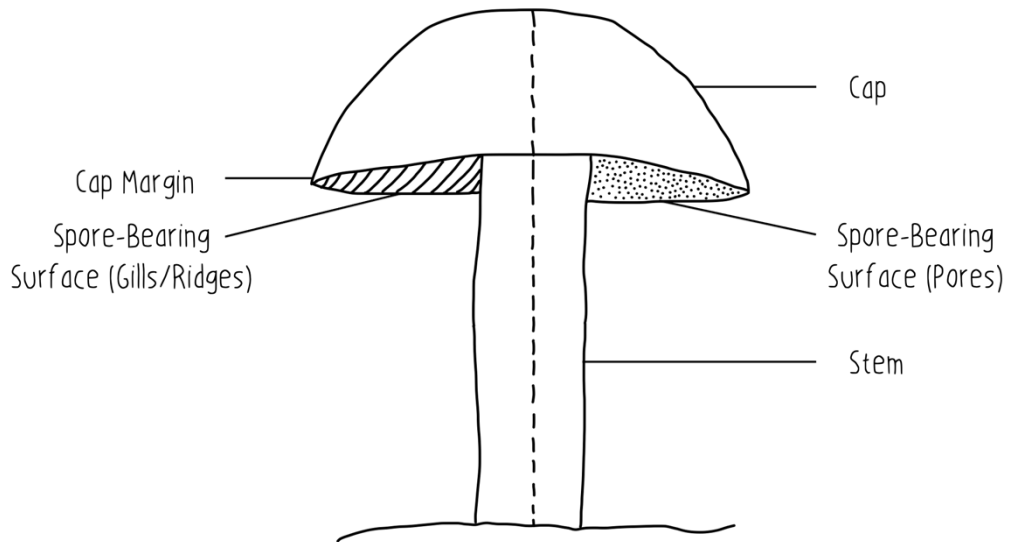

### 1. Structure of the Mushroom

- Clearly defined stem
- Gills/Ridges (lines) or pores (holes) present
- Different structure → jump to page 7 point 5

There maybe one or more check marks possible.

### 2. Cap

#### 2a Cap Shape

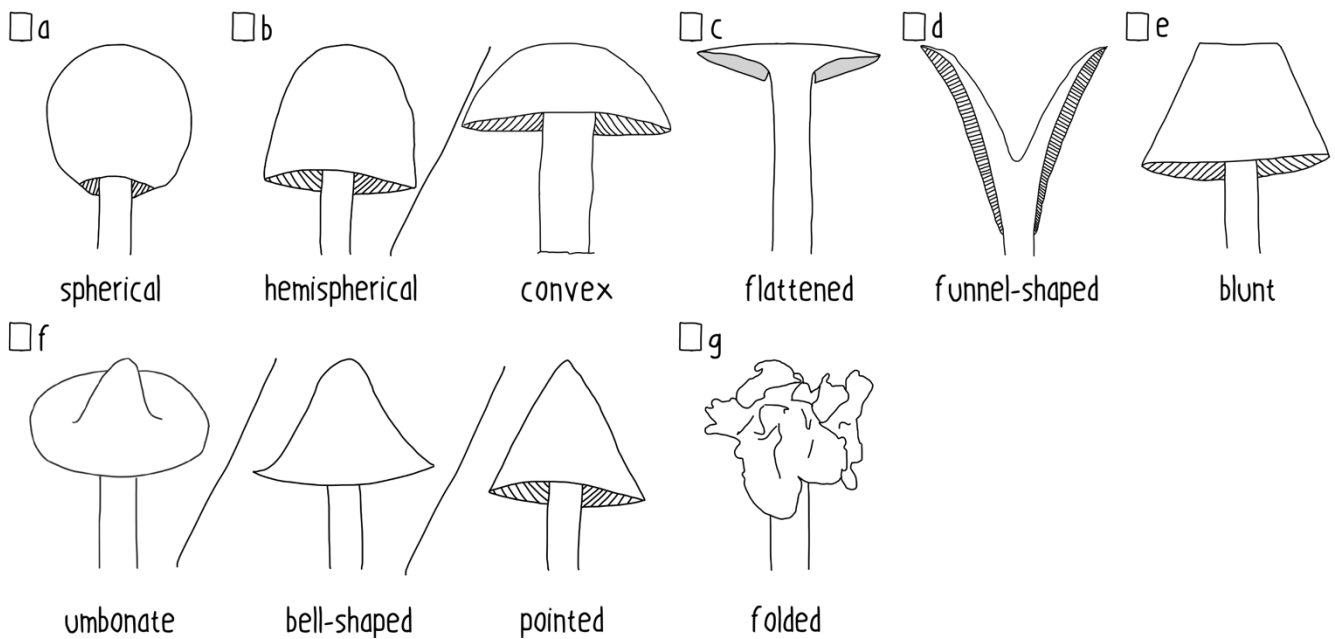

#### 2b Cap Surface

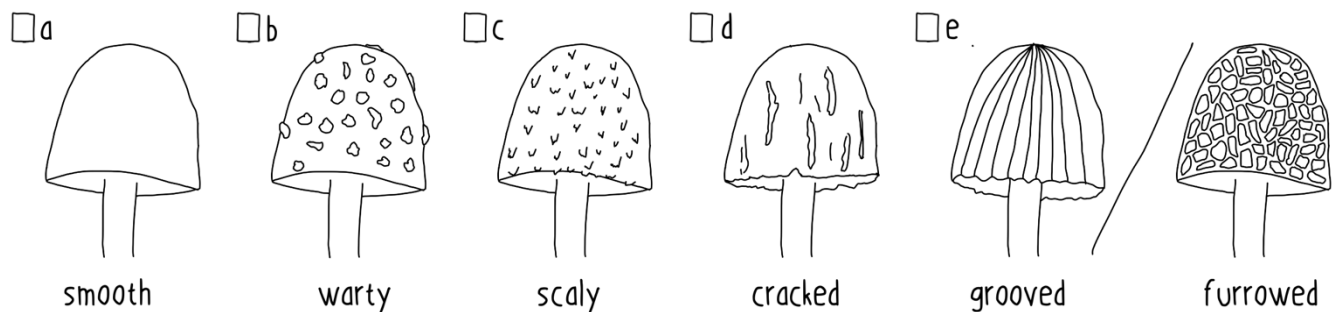

### 2c Cap Color

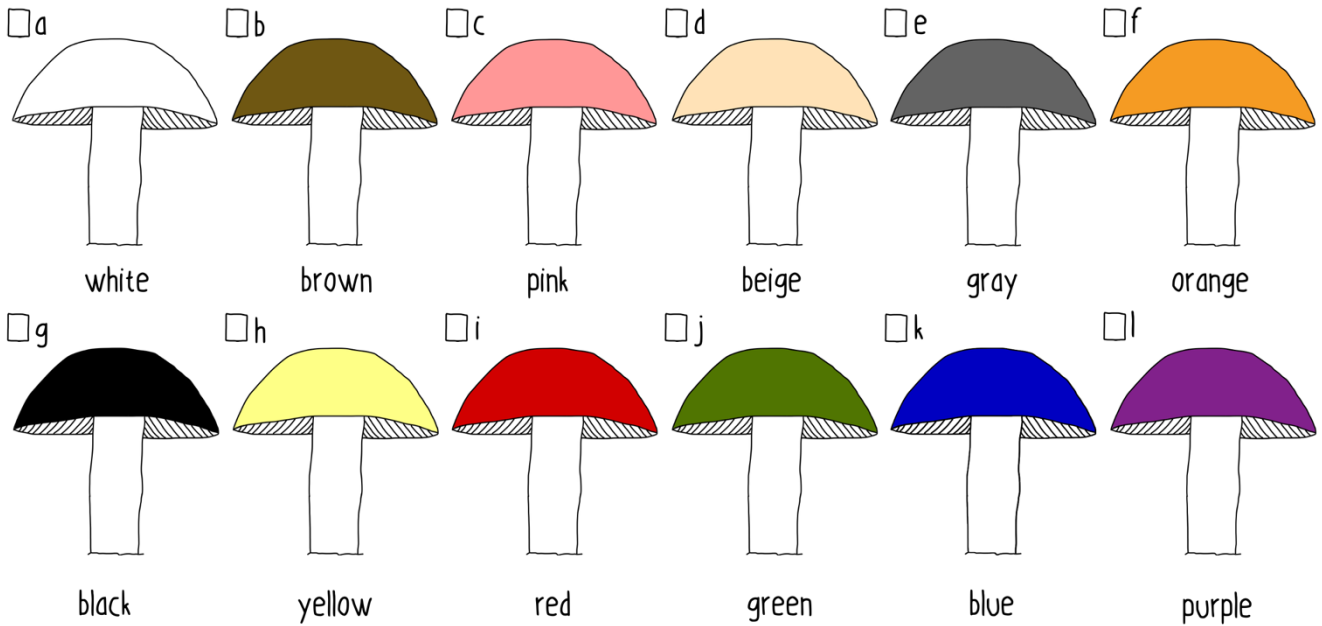

### 2d Comparing Top and Bottom of Cap

- Top and bottom sides are different
- No differences between top and bottom → jump to page 5 point 4

### 2e Cap Surface

- The cap skin extends to the margin
- You can see the spore layer from above-the cap skin doesn't reach the margin

### 2f Cap Margin

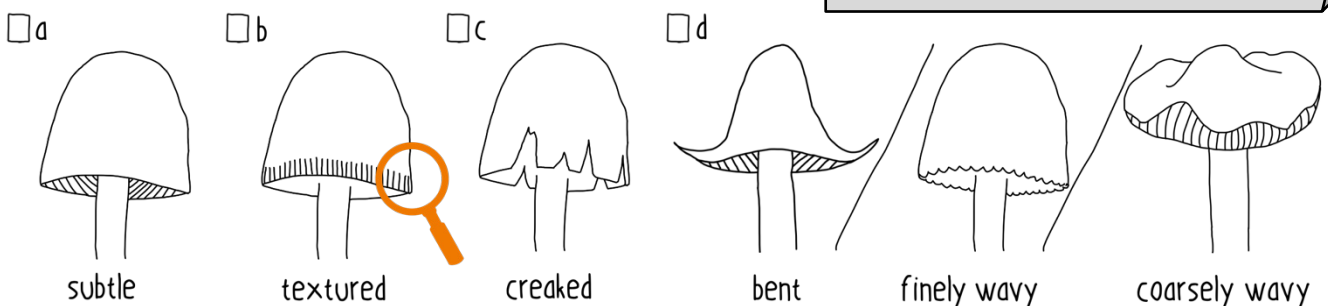

Inwardly rolled margin is not a feature – normal for young mushrooms.



3. Spore Layer

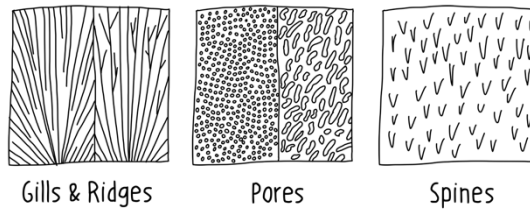

- Spore layer beneath the cap is present
- No spore layer present → jump to page 5, point 4

3a Spore layer color

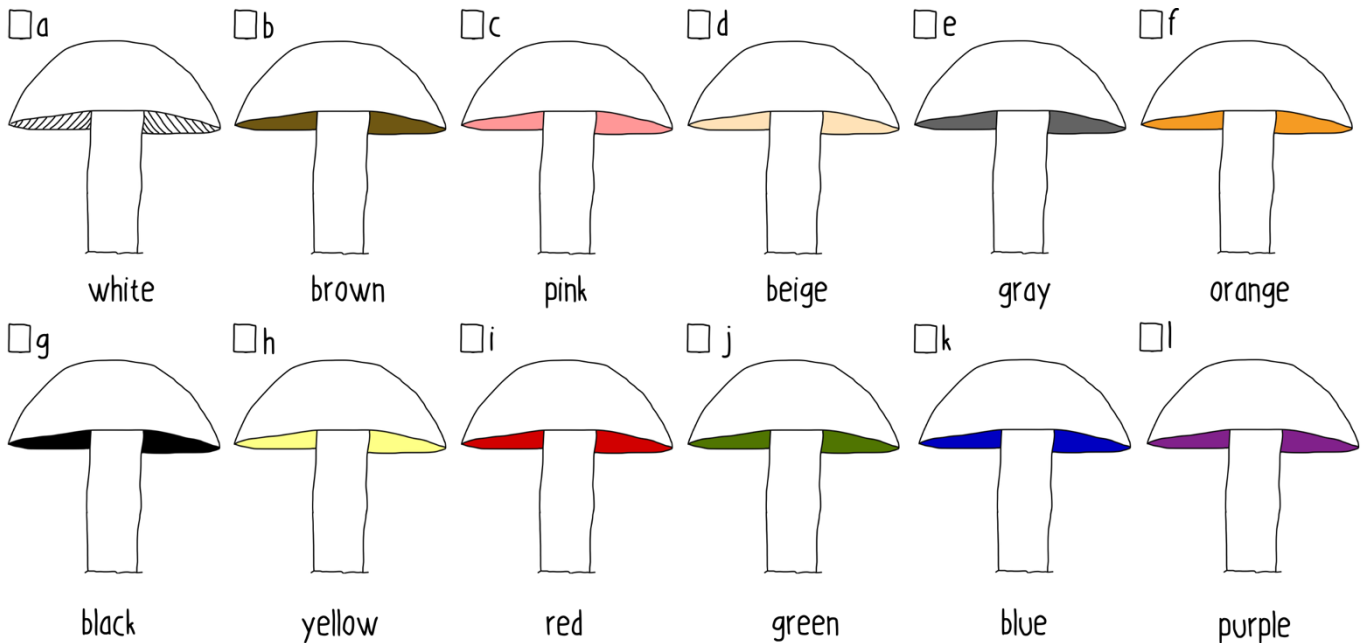

3b Spore layer shape

- The spore layer under the cap is made up of gills or ridges
- The spore layer under the cap is made up of pores → jump to page 5 point 3f
- If neither characteristic applies → jump to page 5 point 4



3c Gill and Ridge Attachment (How do the gills connect to the stem?)

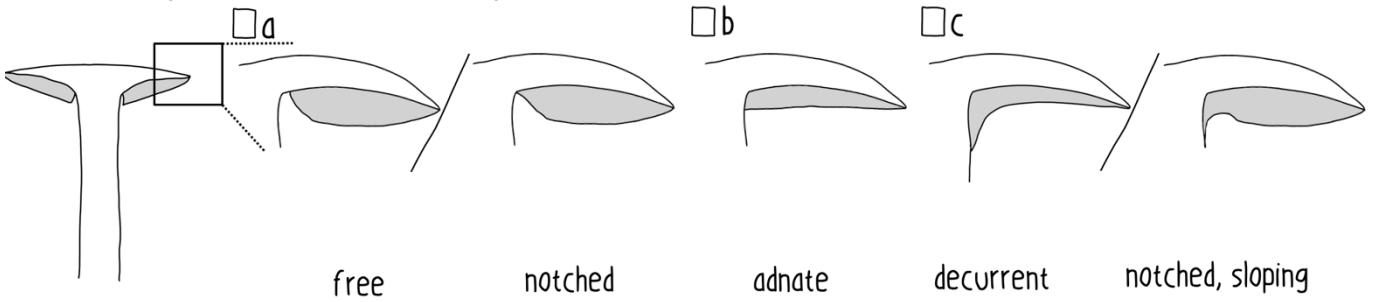

3d Gills and Ridge Margin (What is the structure of the exposed ends of the gills or ridges?)

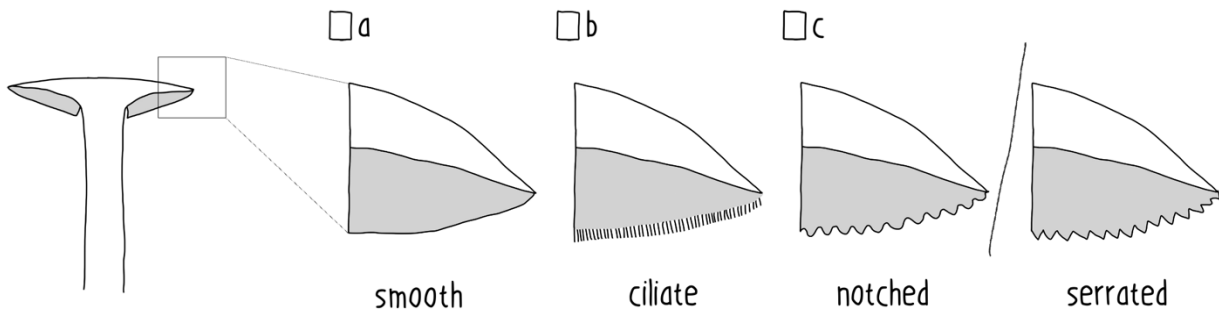

3e Gill and Ridge Arrangement (How are the gills or ridges spaced in relation to each other?)

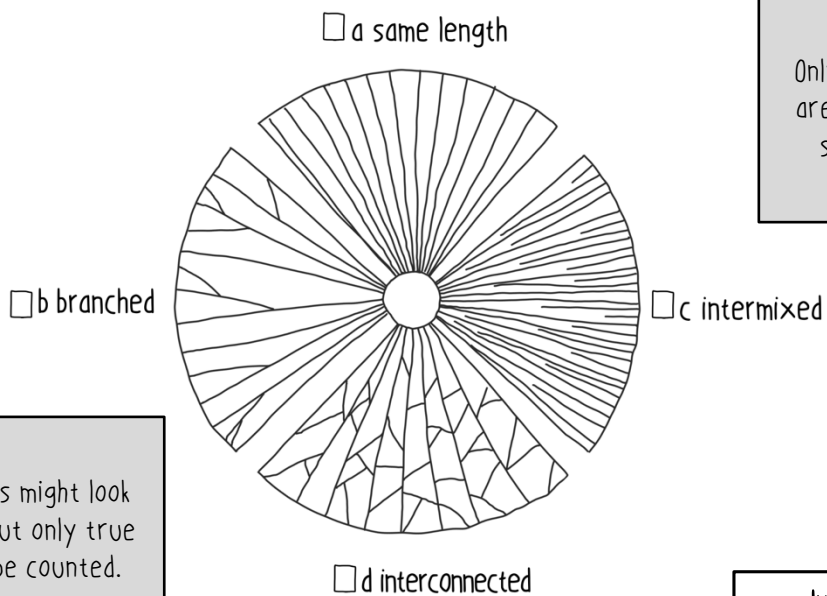

Only regularly shortened gills are considered interspersed; single exceptions do not

Closely spaced gills might look like they branch, but only true branches should be counted.

→ Jump to page 5 point 4

3f Pore Arrangement (What shape and size are the pores?)

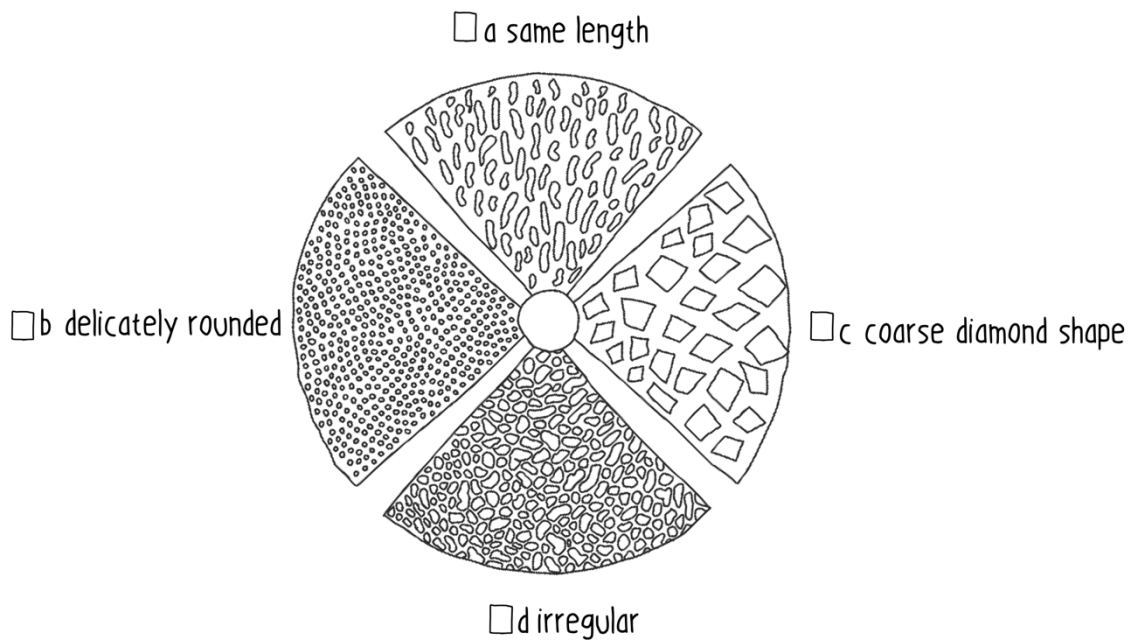

4. Stem

- Stem present
- Stem is very short or missing → jump to page 9 point 6

4a Stem Position (Where is the stem attached to the cap?)

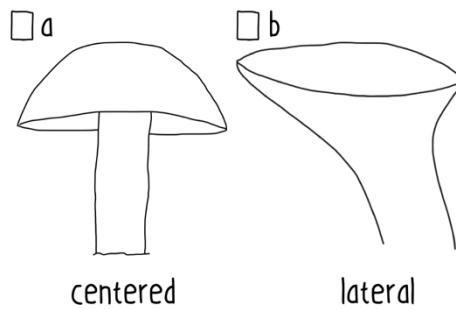

4b Stem Color

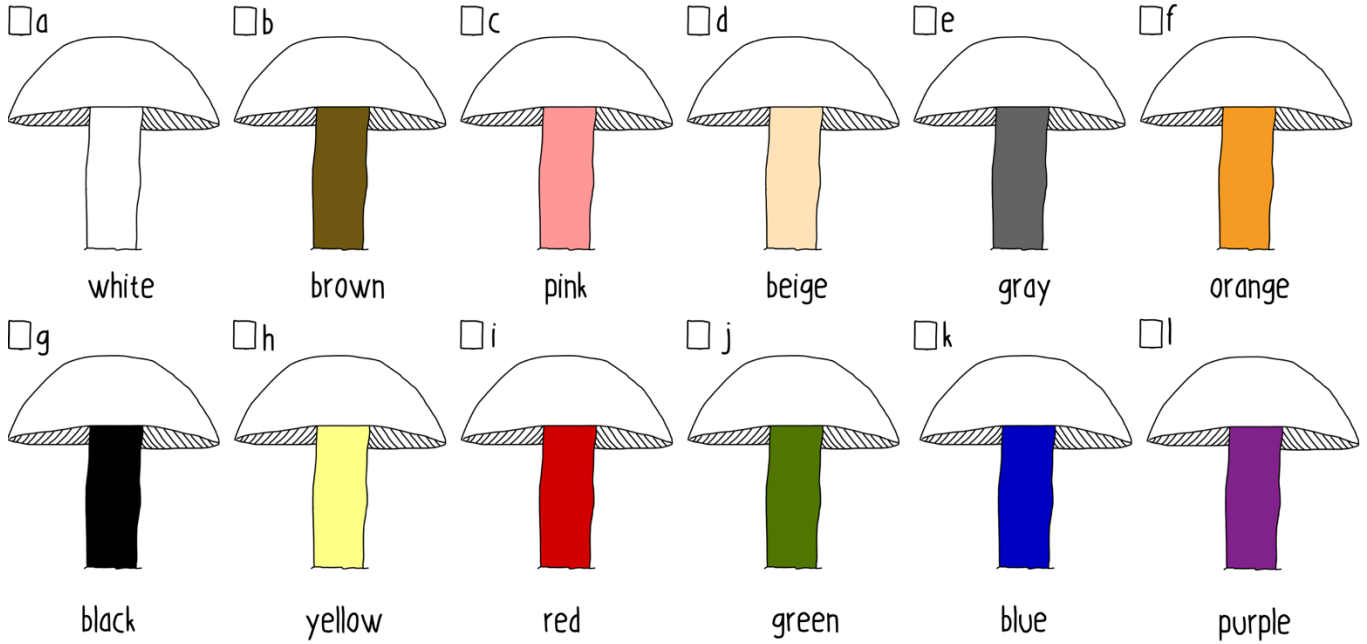

4c Stem Shape

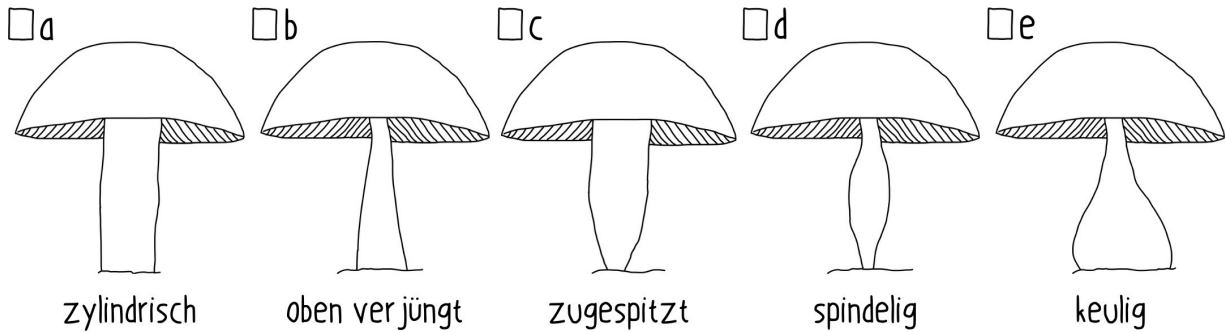

4d Ring and Fiber Remnants on the Stem

The web-like layer comes off easily and is hard to spot; check the margin of the cap as well.

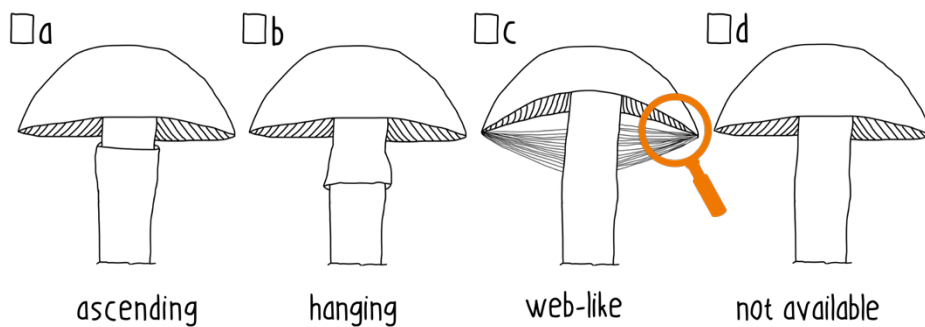

The features aren't always found along the entire system.

4e Stem Characteristics (What is the texture of the stem?)

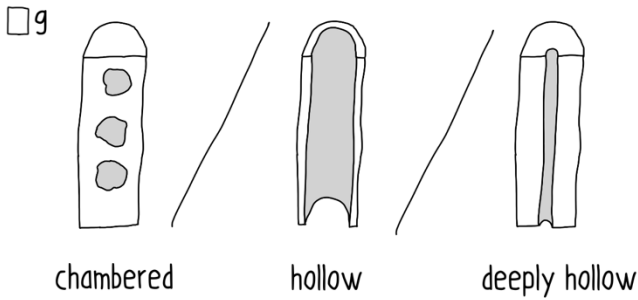
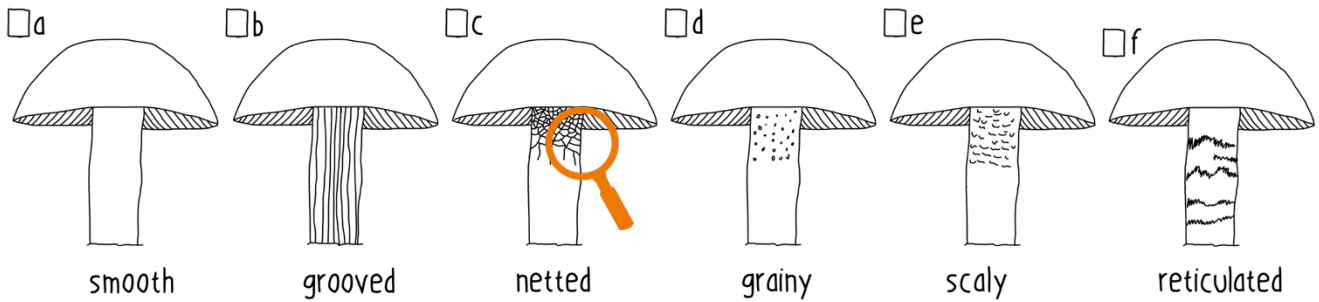

Reticulated is a color pattern, not a structure.

→ jump to page 9 point 6

5. Other Appearance Features

5a Fruiting Body Shape

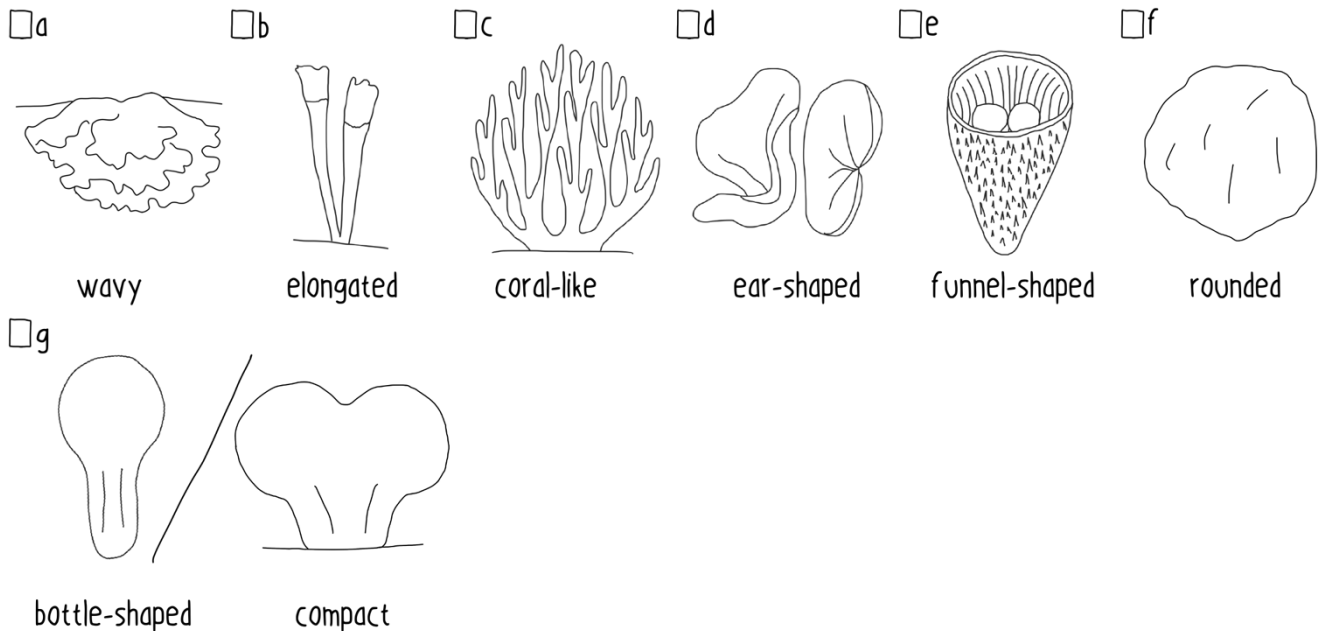

5b. Fruiting Body Surface

a



subtle

b



spiky

c

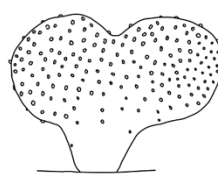

warty

d

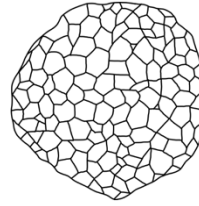

ridged

5c Fruiting Body Color

a

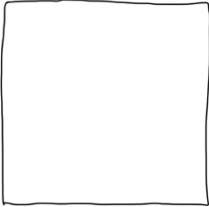

white

b

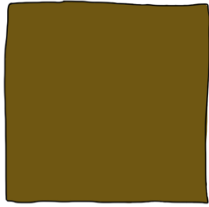

brown

c

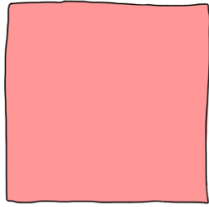

pink

d

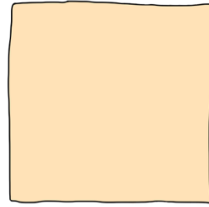

beige

e

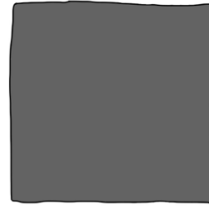

gray

f

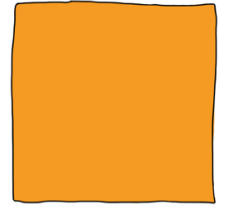

orange

g

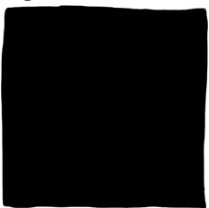

black

h

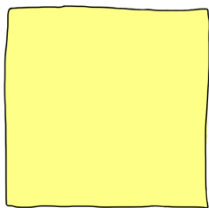

yellow

i

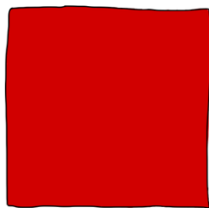

red

j

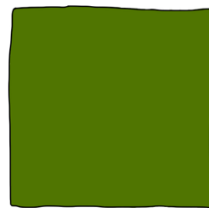

green

k

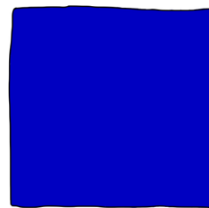

blue

l

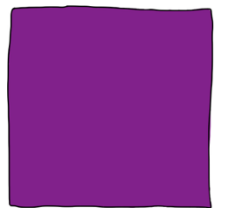

purple



### 6. Flesh (What color is the inside of the mushroom?)

Important: Must be answered for every mushroom!

#### 6a Flesh Color

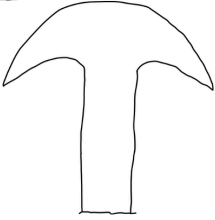
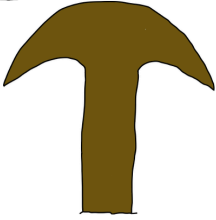
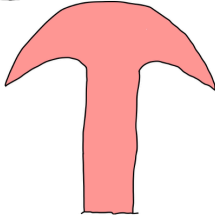
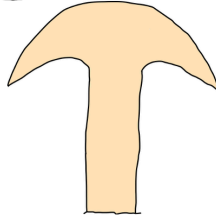
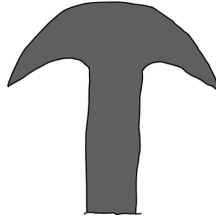
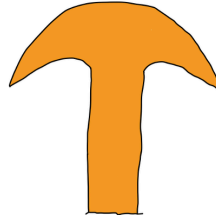
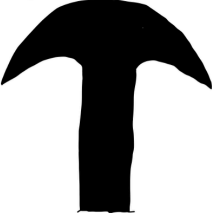
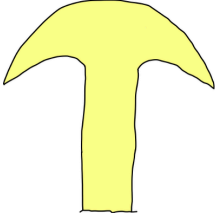
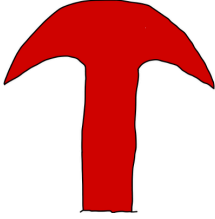
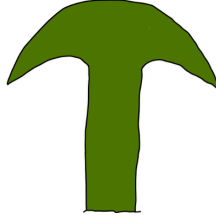
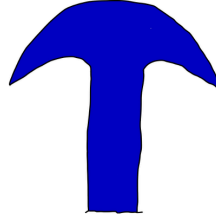
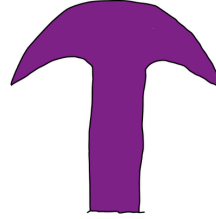
<input type="checkbox"/> a	<input type="checkbox"/> b	<input type="checkbox"/> c	<input type="checkbox"/> d	<input type="checkbox"/> e	<input type="checkbox"/> f
					
white	brown	pink	beige	gray	orange
<input type="checkbox"/> g	<input type="checkbox"/> h	<input type="checkbox"/> i	<input type="checkbox"/> j	<input type="checkbox"/> k	<input type="checkbox"/> l
					
black	yellow	red	green	blue	purple



Want to identify more mushrooms and explore them interactively?

Then head over to



Fungi.Kniffelix.de

www.kniffelix.de is the free hands-on experimentation website, created by the Young Researchers' Initiative Children's Researchers at the TUHH. The aim of the initiative is to make science, technology and research accessible to everyone in a generally understandable way: from everyday life to experimentation to research and career orientation.



This material from Children's Researchers at the TUHH is licensed under the international CC Attribution-NonCommercial ShareAlike 4.0, see: <https://creativecommons.org/licenses/by-sa/4.0/>

**Authors:**

Dr. Frida Meyer-Mandik, Gesine Liese, Julia Husung  
Hamburg 2026

**Children's researchers at the TUHH**

Am Irrgarten 3-9, Building Q, 21073 Hamburg  
Tel. (040) 306014082  
[gesine.liese@kinderforscher.de](mailto:gesine.liese@kinderforscher.de)  
[julia.husung@kinderforscher.de](mailto:julia.husung@kinderforscher.de)  
[www.kinderforscher.de](http://www.kinderforscher.de)

**A working group of  
Prof. Dr. Andreas Liese**

Dernicke Straße 15, Building K, 21073 Hamburg  
Tel. (040) 306013218  
[liese@tuhh.de](mailto:liese@tuhh.de)  
[www.technical-biocatalysis.com](http://www.technical-biocatalysis.com)

We would like to thank the Federal Ministry of Agriculture, Food and Community (BMLEH) for the financial support 281A813B21



[fungi.kniffelix.de](http://fungi.kniffelix.de)



Federal Ministry  
of Agriculture, Food  
and Regional Identity

**TUHH**  
Technische  
Universität  
Hamburg